



EKIN ENDÜSTRİYEL

Hygienic Centrifugal Pumps



Our Main Focus

Heat Transfer Section

- Plate Heat Exchangers
- Brazed Heat Exchangers
- Flat Access Stations
- Shell and Tube Heat Exchangers

Pressure Vessel Section

- Boilers
- Accumulation Tanks
- Stainless Process Tanks
- Expansion Tanks
- Balance Tanks
- Air Separators
- Sediment Blockers

Separator Vessels Section

- Balance Tanks
- Sediment Blockers
- Air Separators
- Package Sediment and Air Separators
- Package Balance Sediment and Air Separators

Hygienic Process Section

- Pasteurizers and Sterilizers
- CIP Systems and Tubular Heat Exchangers
- Complete Stainless Process Heat Exchangers
- Hygienic Pumps
- Aseptic Storage Tanks
- Food Process Equipment and Facilities

Liquid Transfer Section

- Rotary Lobe Pumps
- Barrel Pumps
- Mono Pumps
- Domestic Pumps
- Air Diaphragm Pumps
- Twin Screw Hygiene Pumps
- Magnetic Coupling Centrifug Pumps
- Hygienic Centrifug Pumps
- Peristaltic Hose Pumps
- Dosage Pumps



Sustainable Innovation, Quality Standardization and Dynamism

Ekin Industrial has entered Turkey's sector of imported plate heat exchanger, with their customer focused vision and dynamic. Ekin has expanded into new and upcoming investments.

One of the main steps was gaining the identity of being a producer. Ekin Industrial has started the production of plate heat exchangers with the brand of 'MIT'. We grew in the philosophy of quality, through initially adapting to ISO Quality Management System procedures, and completed the CE security and quality certification period, and has matched foreign standards like GOST.

MIT plate heat exchangers have now become a solution to engineering problems in the world market and has grown through an expansion of franchises.

Engineering Approachments, Integrated Solutions

Ekin Industrial, with investment in MIT plate heat exchangers, their identity of producer and engineer vision is aiming to solve problems in the sector. To meet these views, Ekin Industrial has expanded into the production of components, sales and after sales service by employing expert engineers.

The factors that guided Ekin Industrial to success are their exceptional customer service to the needs and wants of consumers, modern facilities, and becoming partners to projects that involve high-end technology.

Ekin Industrial is an expert company which has wide product range which includes plate heat exchangers, accumulation tanks, water heater tanks, installation materials and its service group and submit competitive advantages to mechanical installation sector in Turkey and all around the World.



MIT HYGIENIC CENTRIFUGAL PUMPS

MIT hygienic centrifuge pumps are used in food, pharmaceutical and cosmetics industries. Clamp type connection is used. 316 L stainless steel is used for body material.

Special design of its fan and cover it reduces friction and eliminates non hygienic blind spots. Also with the special design velocity of the fluid reaches maximum levels and with easy montage and de-montage it gives user easy maintenance and cleaning option.

Technical features:

Max flow rate: 150 m³/h

Max Head: 70 m

Max Temperature: 120°C (30 minutes at CIP/SIP applications)

Max rpm: 3600 rpm

Materials;

Body and Fan: AISI 316L

Gasket: EPDM (suitable for food)

Mechanical shaft seal

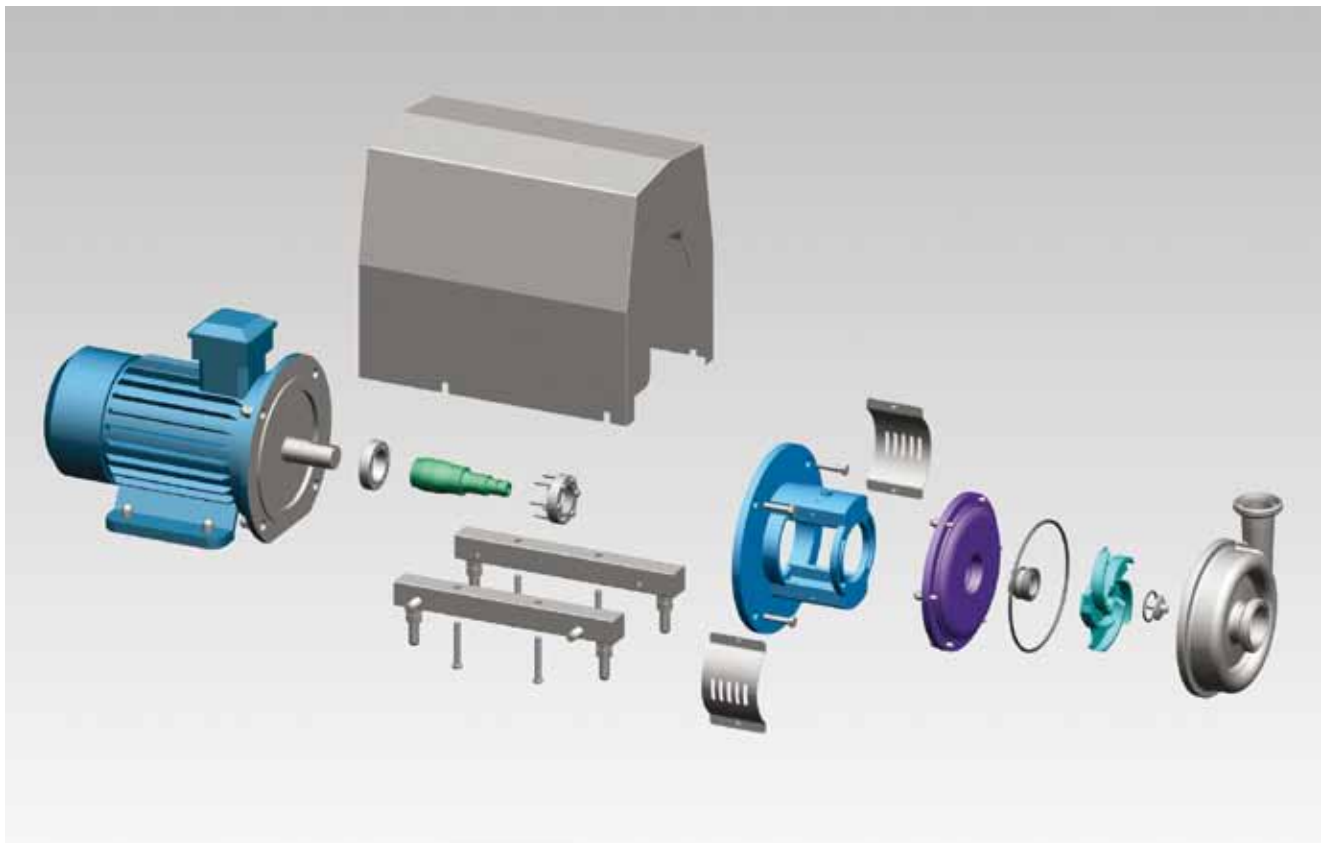

Inclusive Performance Curve

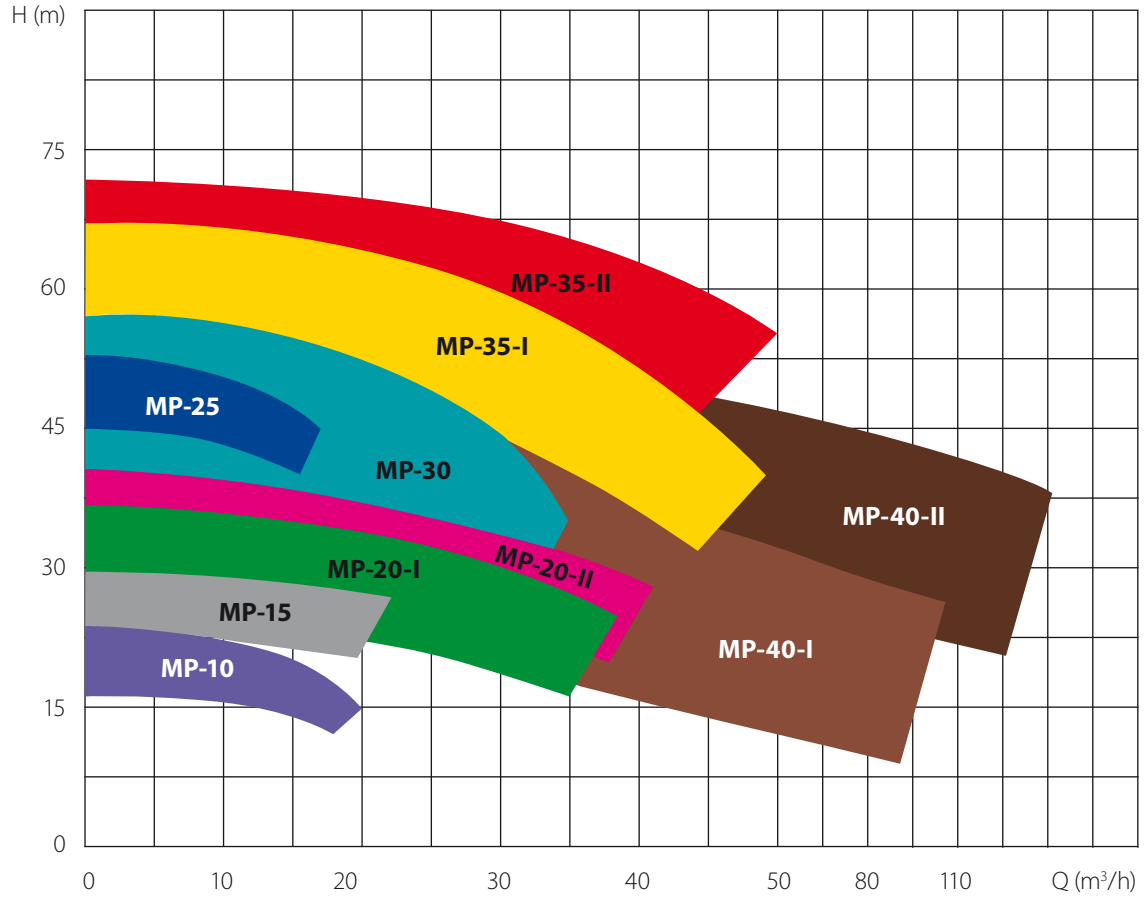

MIT Hygienic Centrifugal Pump Schedule

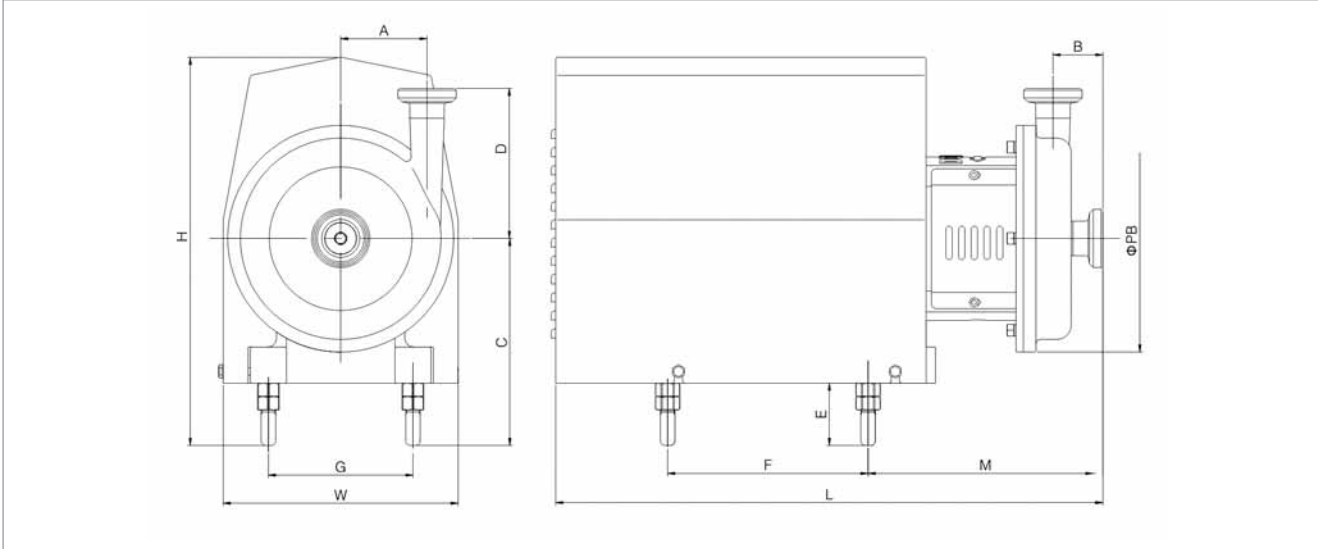

Model	Motor kW			PB	ø	A	B	C	D	M	F	G	H	L	W	E	C	H	E
MP-10	1,5	1,5"	1,5"	189	32	63	60	190	136	163	240	140	360	528	210	70	222	392	102
	2,2	1,5"	1,5"	189	32	63	60	210	136	163	240	140	360	528	210	70	242	392	102
MP-15	1,5	2"	1,5"	250	32	90,5	42	190	155	186	240	140	360	551	210	70	222	392	102
	2,2	2"	1,5"	250	32	90,5	42	210	155	186	240	140	360	551	210	70	242	392	102
MP-20-I MP-20-II	2,2	2"	2"	250	32	85	45	210	170	186	240	140	360	551	210	70	242	392	102
	3	2"	2"	250	32	85	45	230	170	175	300	160	430	599	260	70	262	462	102
	4	2"	2"	250	32	85	45	222	170	175	300	190	430	599	260	70	254	462	102
	5,5	2"	2"	250	32	85	45	252	170	197	330	216	470	737	310	70	284	502	102
MP-25	4	2"	1,5"	268	32	108	56	222	190	173	300	190	430	597	260	70	254	462	102
	5,5	2"	1,5"	268	32	108	56	252	190	195	330	216	470	735	310	70	284	502	102
MP-30	5,5	2"	1,5"	268	32	108	56	252	190	195	330	216	470	735	310	70	284	502	102
	7,5	2"	1,5"	268	32	108	56	252	190	195	330	216	470	735	310	70	284	502	102
MP-35-I	11	2,5"	1,5"	350	36	131	68	290	229	240	450	254	575	860	375	102	322	607	102
	15	2,5"	1,5"	350	36	131	68	290	229	240	450	254	575	860	375	102	322	607	102
MP-35-II	15	2,5"	2"	350	36	131	68	290	229	240	450	254	575	860	375	102	322	607	102
	18,5	2,5"	2"	350	36	131	68	290	229	240	515	254	575	885	375	102	322	607	102
MP-40-I MP-40-II	11	3"	2,5"	303	36	105	73,5	290	213,5	240	450	254	575	870	375	102	322	607	102
	15	3"	2,5"	303	36	105	73,5	290	213,5	240	450	254	575	870	375	102	322	607	102
	18,5	3"	2,5"	303	36	105	73,5	290	213,5	240	515	254	575	895	375	102	322	607	102
	22	3"	2,5"	303	36	105	73,5	310	213,5	240	515	279	625	946	400	102	342	657	102
	30	3"	2,5"	303	36	105	73,5	330	213,5	267	580	318	670	1014	440	102	362	702	102

Performance Curve

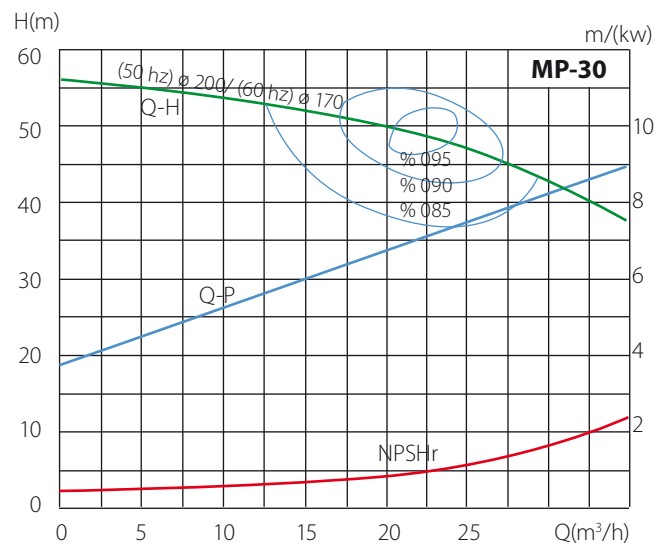
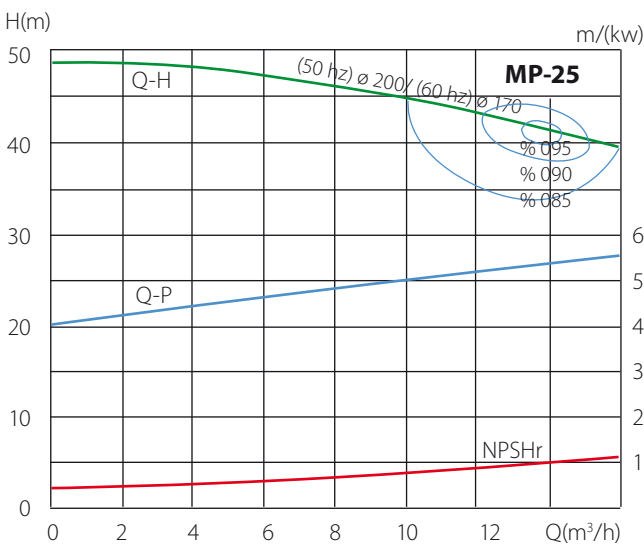
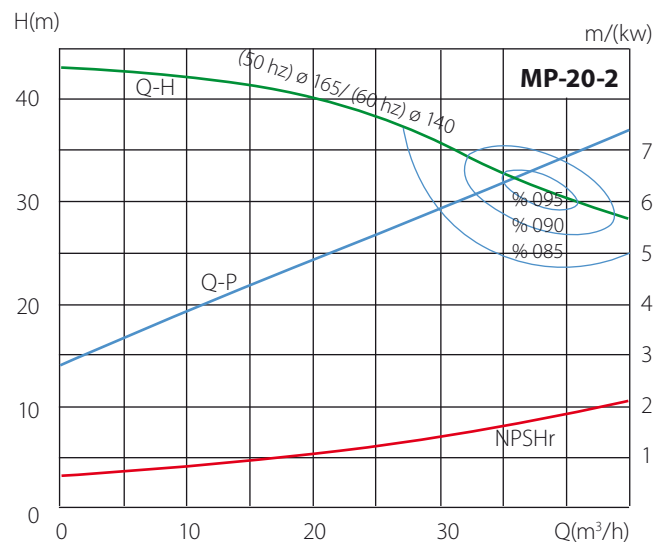
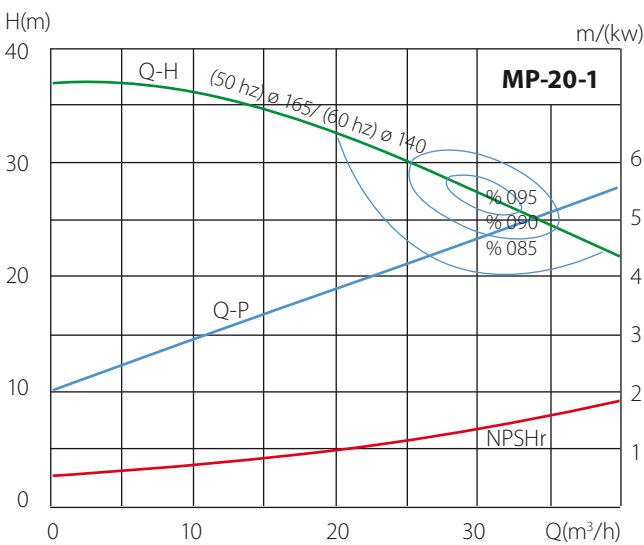
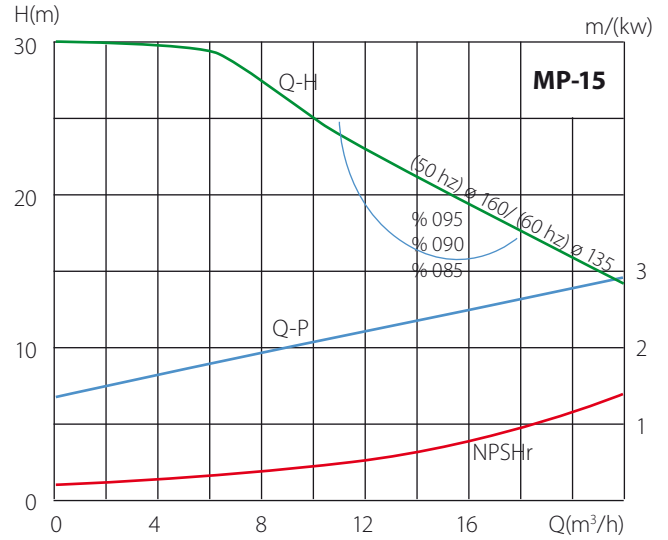
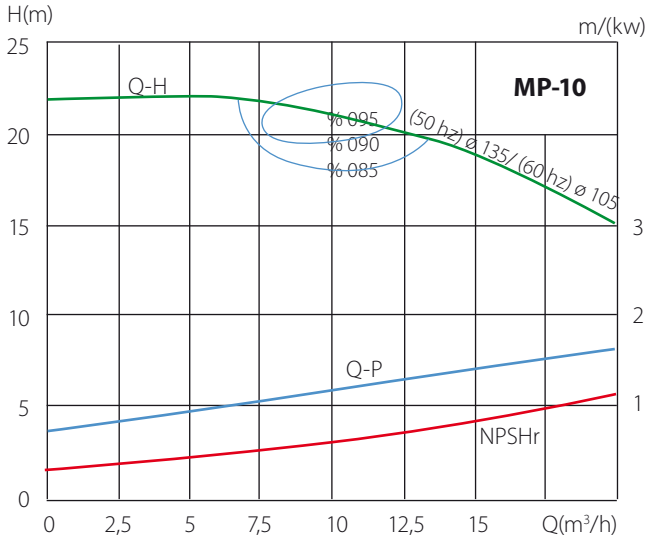

Performance Curve

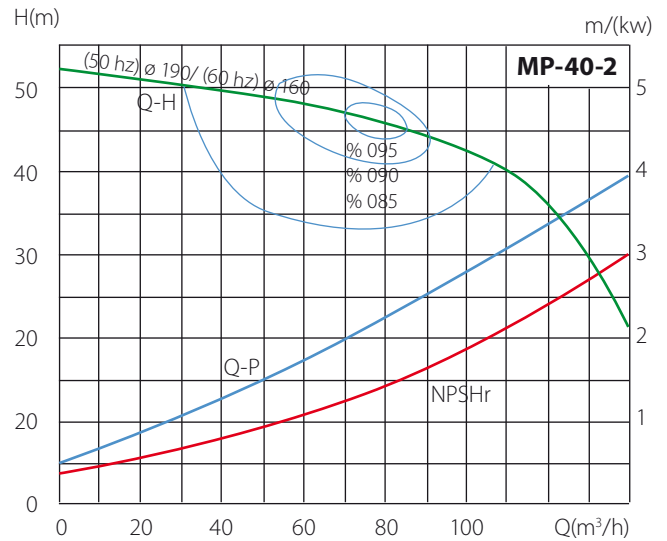
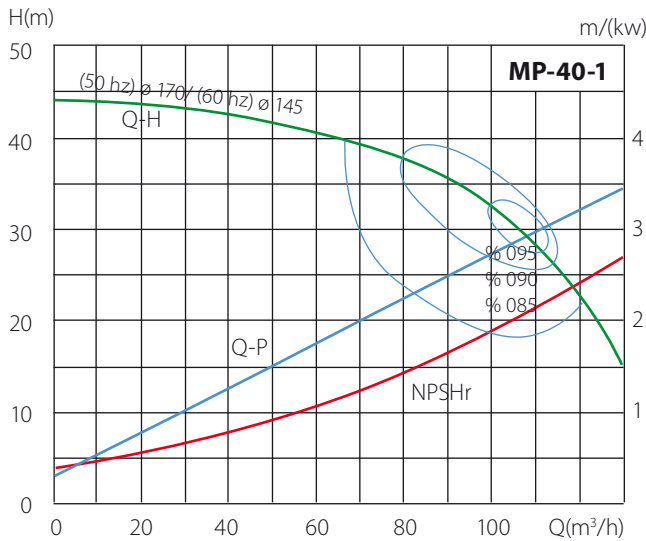
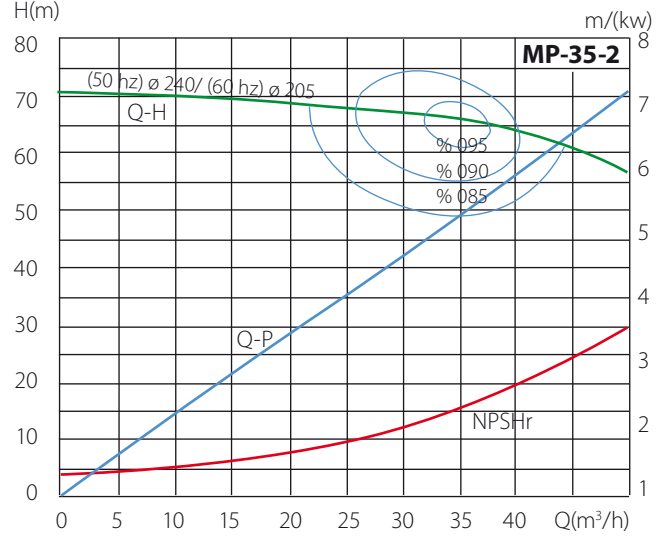
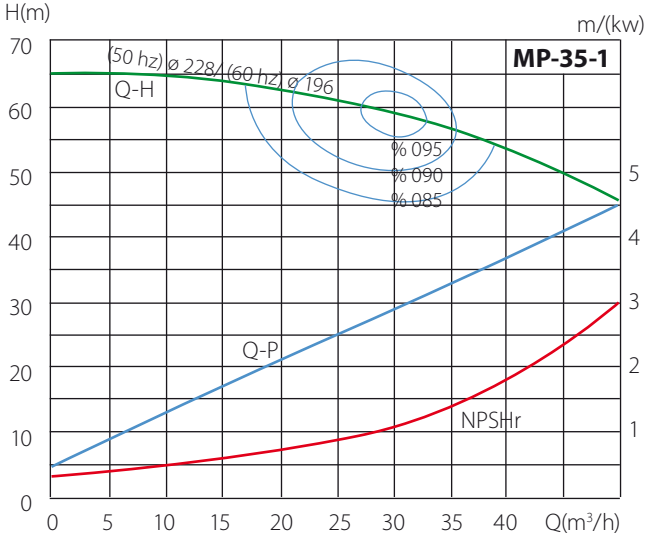

Optional Features

MIT hygienic centrifuge pumps can be produce in various options.

It can be easily used on a wheeled chassis portably and with adding a control panel to this chassis.

Only thing here is to connect the control panel to a power grid.



50 Reasons for Choosing MIT

WHEN YOU BUY A MIT PUMP;

You will have a well-known brand all around the world.

WHEN YOU BUY A MIT PUMP;

You will have longest and most comprehensive warranty.

WHEN YOU BUY A MIT PUMP;

You will have fastest delivery time.

WHEN YOU BUY A MIT PUMP;

You will have the best quality.

WHEN YOU BUY A MIT PUMP;

You will have cheapest price.

WHEN YOU BUY A MIT PUMP;

You will work with main manufacturer.

WHEN YOU BUY A MIT PUMP;

You will have fastest spare part delivery time.

WHEN YOU BUY A MIT PUMP;

You will have fastest and largest service network.

WHEN YOU BUY A MIT PUMP;

You will have a good which has ISO, CE, GOST, TSE certificates.

OUR MIT PUMPS;

Designed for easy demontage and service.

AT OUR MIT PUMPS;

Dosage systems can be installed as per your request.

AT OUR MIT PUMPS;

Brand certificates are granted with CE and ISO Labels.

AT OUR MIT PUMPS;

We use stainless steel for hygienic materials.

AT OUR MIT PUMPS;

All our products are tested with precaution.

AT OUR MIT PUMPS;

We have montage foots to back up the pumps.

AT OUR MIT PUMPS;

Aggressive and corrosive resistant materials are used.

AT OUR MIT PUMPS;

Best quality materials are used for high resistance.

AT OUR MIT PUMPS;

Different gasket options are available.

AT OUR MIT PUMPS;

We make direct contact with manufacturer.

AT OUR MIT PUMPS;

We guarantee as producer.

AT OUR MIT PUMPS;

They are easily montaged.

AT OUR MIT PUMPS;

We offer different materials for different applications.

AT OUR MIT PUMPS;

We offer special pumps for applications.

AT OUR MIT PUMPS;

We offer different type of connection systems based on your applications.

AT OUR MIT PUMPS;

We offer different models of pumps based on your applications.

AT OUR MIT PUMPS;

Our experienced, friendly and solution based service personals are available 7/24.

WHEN YOU WOULD LIKE TO BUY A MIT PUMP;

You will make contact with experienced personals on pumps.

WHEN YOU WOULD LIKE TO BUY A MIT PUMP;

You can contact global network based on sales in Turkey.

WHEN YOU WOULD LIKE TO BUY A MIT PUMP;

We can supply side materials besides pumps.

WHEN YOU WOULD LIKE TO BUY A MIT PUMP;

Sales are done by mechanical engineers precisely and traced very carefully.

WHEN YOU WOULD LIKE TO BUY A MIT PUMP;

You will have opportunity to work with a team who will be available all days and all hours.

WHEN YOU WOULD LIKE TO BUY A MIT PUMP;

We offer quick solutions.

WHEN YOU WOULD LIKE TO BUY A MIT PUMP;

Our first priority is customer pleasure.

WHEN YOU WOULD LIKE TO BUY A MIT PUMP;

You can get information about all your system not just pumps.

WHEN YOU WOULD LIKE TO BUY A MIT PUMP;

Our exploration service will serve you the best solution.

WHEN YOU WOULD LIKE TO BUY A MIT PUMP;

You won't need to follow useless procedures.

WHEN YOU WOULD LIKE TO BUY A MIT PUMP;

You can get an exchanger education at you company or ours.

WHEN YOU WOULD LIKE TO BUY A MIT PUMP;

You can get large information and documentation support.

WHEN YOU WOULD LIKE TO BUY A MIT PUMP;

You can get consult us for your all problems.

Professional System Solution Center

You can take assistance about problems you have from MIT Plate Heat Exchanger Solution Center. Our solution center having qualified mechanical engineers will be happy to help you. These are some of the subjects that we can happily help you;

Steam installations

- Utility hot water installations
- Central and local heating systems
- Milk, yogurt, airan heating, cooling and pasteurization
- Industrial heating and cooling systems
- Oil cooling installations
- Energy recycle systems
- Pool heating systems



+90 444 35 46

In Plate Heat Exchanger systems, it is vital to setup the system correctly to get the desired capacity. That is why, when you set-up your system you can take needed assistance from first hand just using a phone (+90 444 35 46) for 7 days and 24 hours.

To make your system and heat exchangers work correct and full performance, we want to share the information we've had through the long years. It really is a big happiness for us.

We want to emphasize that again and again. Ekin Endüstriyel will continue being the best solution partner in every place where heat exchanger is used.



You are in exact point where quality,
experience and technology meet

Our Quality Certificates:





Ekin Endüstriyel Isıtma-Soğutma San. Tic. Ltd. Şti.
DES San. Sit. 107. Sok. No:2 Y. Dudullu / Ümraniye / İstanbul
Phone : +90 444 35 46
Fax : +90 216 660 13 08
E-mail : info@ekinendustriyel.com
Web : www.ekinendustriyel.com

